



苏州汇利得机械有限公司
Suzhou Huilide Machine Co.,Ltd

提供排序和给料方案
Provide sorting and feeding Solutions
Add:No. 25,Yangjiajiao,
Yangchenghu,Xiangcheng,Suzhou,
China,215138
Tel:+86-150 0613 9272
Email:info@hldmachine.com
www.hldmachine.com

柔性振动平台 Flexible vibratory feeder

柔性振动平台是高性能、柔性强的给料系统。我们的柔性振动平台利用振动技术和视觉系统来保证上料速度快、精度高和柔性强的优点。这消除了不同物料更新不同设备的时间和减少占用生产空间。

Flexible vibratory feeder is one high performance of flexible sorting and feeding system. Our vibration technology with vision system makes sure that our flexible vibratory feeder can reach optimized speed, accuracy and flexibility. This eliminates expensive changeover times and frees up valuable production space for other uses.

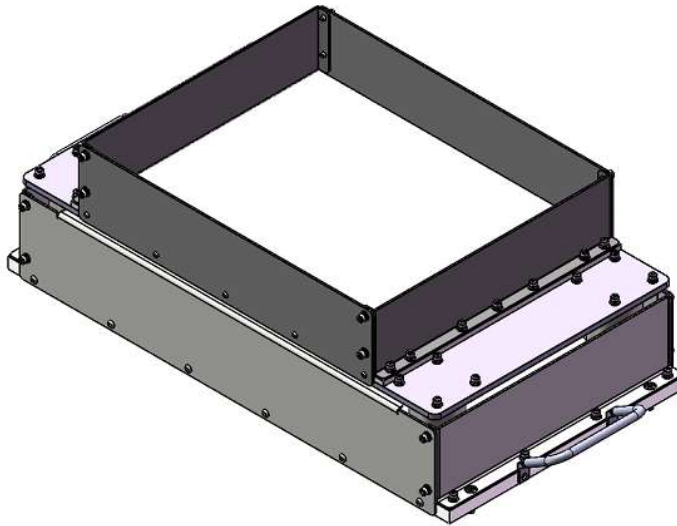

技术规格 Specification

尺寸 Dimensions(mm)

型号 Model	A	B	C	D	物料尺寸范围 Part size
FF-00	70	50	312	77	0.5-4
FF-01	150	100	450	107	3-10 或 or<15 细长件物料 long and thin
FF-02	205	160	318	167	3-30 或 or<50 细长件物料 long and thin
FF-03	294	230	450	234	5-50 或 or<70 细长件物料 long and thin
FF-04	394	310	550	314	15-80 或 or<100 细长件物料 long and thin
FF-05	384	494	650	400	20-120 或 or<150 细长件物料 long and thin

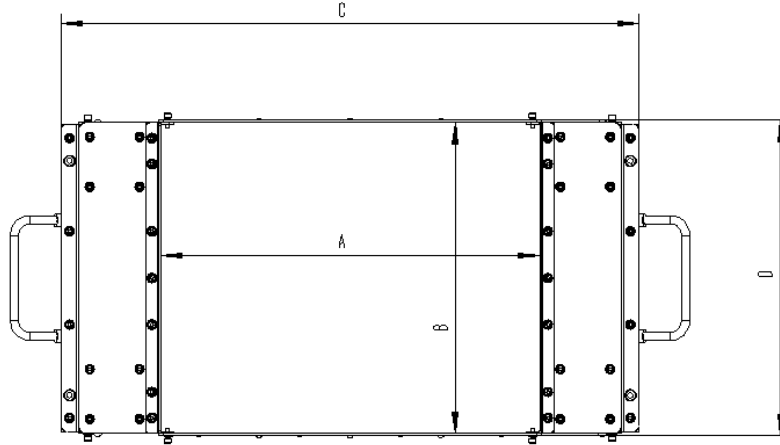

电气 Electrical

通信方式 Communication	RS485、I/O
电源 Power	DC 24V 8A
机械手 Software plug-in	FAUNC、Adept、EPSON、ABB、UR

其他可选 Options

LED 背光源 Integrated LED backlight	红、绿、蓝、白、紫外线/red、green、blue、white、infrared
振动槽 vibratory pan	平、孔、槽、巢等 Flat/holes/grooves/nests/various materials
料仓 hopper	根据要求 As requirements
槽材质 pan material	根据要求 As requirements

我们的服务包括 Our services are below:

初步分析 Preliminary analysis

技术支持和柔性测试 Technical supporting and feasibility test

布局和节拍优化 Layout and cycle time optimization

设备设计 Equipment design

实时支持和诊断 Real-time assistance and diagnose

培训 Training

试运行期间在线支持 On-site supporting for system Ramp-up

远程支持 Remote supporting